

Free of maintenance stop valve with bellows seal - metallic sealing

**ARI-FABA® LongLife -
Straight through with flanges**

- German TA - Luft TÜV-Test-No. 088-945053
- TRB 801 Annex II No. 45

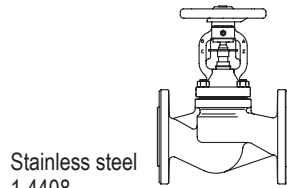

Stainless steel
1.4408

Fig. 046

Page 2

**ARI-FABA® LongLife -
Y-pattern with flanges**

- German TA - Luft TÜV-Test-No. 088-945053
- TRB 801 Annex II No. 45

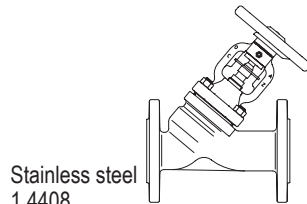

Stainless steel
1.4408

Fig. 069

Page 3

**ARI-FABA® LongLife -
Y-pattern with butt weld ends**

- German TA - Luft TÜV-Test-No. 088-945053
- TRB 801 Annex II No. 45



Stainless steel
1.4571/1.4439

Fig. 066

DN15-50

Page 4

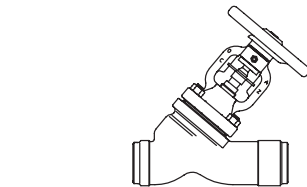

Stainless steel
1.4581/1.4439

Fig. 066

DN65-200

Page 5

FABA®
LONG LIFE

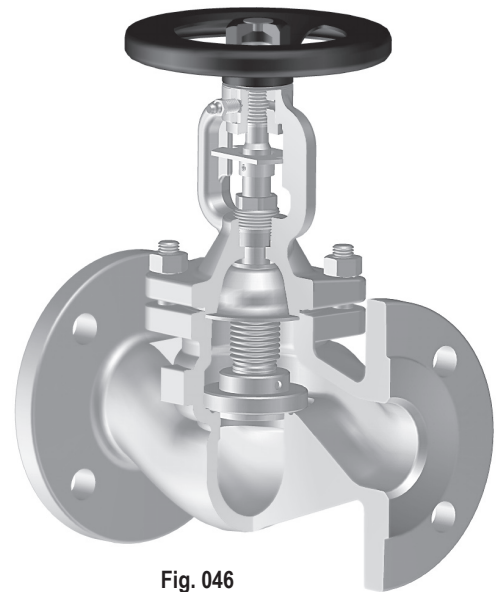

Fig. 046

*For standard casting / forged versions
refer to data sheet „FABA® Long Life“
For ANSI versions
refer to data sheet „ARI-FABA®-ANSI LongLife“*

Features:

- Two-ply bellows seal as standard
- Fig. 046/069: DN 15-100 throttling plug as standard
- Fig. 066: Stellite plug with marginal seat (optional regulating plug)
- DN 15- 80 stem with fine thread as standard
- Lubricating nipple as locking device as standard
- Heat dissipating bonnet
- Stem with bellows seal
- Secondary sealing: gland packing
- Position indicator as standard
- Non-rising handwheel
- Non-rotation lock for each nominal diameter
- External stem thread
- Stem with roll hardened thread

Stop valve - straight through with flanges and bellows seal (Stainless steel 1.4408)

Figure-No.	Nominal pressure	Material	Nominal diameter
52.046	PN16	1.4408	DN15-200
62.046	PN16	1.4408 Body / 1.0619+N Cover	DN15-200
54.046	PN25	1.4408	DN200
64.046	PN25	1.4408 Body / 1.0619+N Cover	DN200
55.046	PN40	1.4408	DN15-150
65.046	PN40	1.4408 Body / 1.0619+N Cover	DN15-150

Test: • German TA - Luft TÜV-Test-No. 088-945053

At high differential pressures a balancing plug is necessary! (refer to page 7)

 DN15-100: Throttling plug as standard
 (for max. permissible ΔP refer to: Flow diagram)

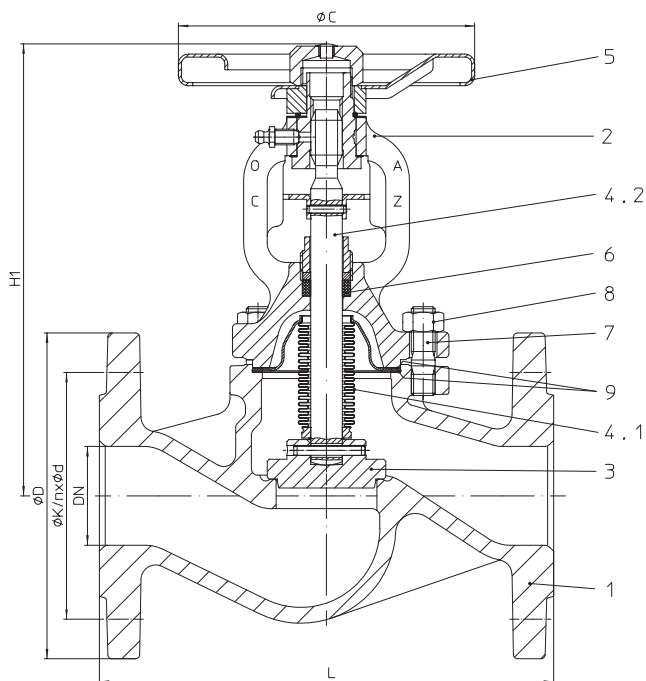
Selection of possible applications

Recycling facilities, chemical industry, hospital technology, process water installations, installations with aggressive media (other applications on request)

Selection of possible flow media

Process water, aggressive media, etc. (other flow media on request)

Parts

Pos.	Description	Fig. 52.046 / Fig. 54.046 / Fig. 55.046	Fig. 62.046 / Fig. 64.046 / Fig. 65.046
1	Body	GX5CrNiMo19-11-2, 1.4408 casted	
2	Bonnet	G-X 5 CrNiMoNb 19-11-2, 1.4581	GP240GH+N, 1.0619+N
3	Plug *	X6CrNiMoTi17 12 2, 1.4571	
4.1	Bellows seal *	X6CrNiMoTi17 12 2, 1.4571	
4.2	Stem *	X6CrNiMoTi17 12 2, 1.4571	
5	Handwheel	≤DN150: St (WEMA COR - coating) / >DN150: EN-JL1040, EN-GJL-250 (WEMA COR - coating)	≤DN150: St (epoxy-coating) / >DN150: EN-JL1040, EN-GJL-250 (epoxy-coating)
6	Packing ring *	Pure graphite	
7	Stud	A4-70	25CrMo4, 1.7218
8	Hexagon nut	A4	C35E, 1.1181
9	Gasket *	Pure graphite (CrNi laminated with graphite)	

* Spare part

Information / restriction of technical rules need to be observed!

Operating instructions can be ordered by phone +49 (0)5207 / 994-0 or fax +49 (0)5207 / 994-158 or -159.

A production allowance acc. to TRB 801 No. 45 exists

The engineer, designing a system or a plant, is responsible for the selection of the correct valve.

Dimensions

	DN	15	20	25	32	40	50	65	80	100	125	150	200
L	(mm)	130	150	160	180	200	230	290	310	350	400	480	600
H1	(mm)	205	205	210	210	225	230	245	265	365	395	425	550
ØC (PN16/25)	(mm)	126	126	126	126	150	150	175	175	225	300	400	520
ØC (PN40)	(mm)	126	126	126	126	150	150	175	225	300	300	400	520
Travel	(mm)	6	6	8	8	13	13	16	20	25	32	40	50
Kvs-value	(m³/h)	4,7	7,4	11,2	18,3	29,3	44,2	73,2	112,2	173	288	410	725
Zeta-value	--	3,7	4,7	5	5	4,8	5,1	5,3	5,2	5,3	4,7	4,8	4,9

Zeta-value ... range of tolerance for Kvs-values acc. to VDI/VDE 2173

Standard-flange dimensions refer to page 9

Face-to-face dimension FTF series 1 according to DIN EN 558

Weights

Figure-No.	DN	15	20	25	32	40	50	65	80	100	125	150	200
52. / 54. / 62.046	(kg)	4,3	4,8	6,3	7,3	10,3	12,6	19	25	33	53	71	144
55. / 64. / 65.046	(kg)	4,3	4,8	6,3	7,3	10,3	12,6	19	26	35	56	74	144

Stop valve - Y-pattern with flanges and bellows seal (Stainless steel 1.4408)

Figure-No.	Nominal pressure	Material	Nominal diameter
52.069	PN16	1.4408	DN15-200
62.069	PN16	1.4408 Body / 1.0619+N Cover	DN15-200
54.069	PN25	1.4408	DN200
64.069	PN25	1.4408 Body / 1.0619+N Cover	DN200
55.069	PN40	1.4408	DN15-150
65.069	PN40	1.4408 Body / 1.0619+N Cover	DN15-150

Test: • German TA - Luft TÜV-Test-No. 088-945053

At high differential pressures a balancing plug is necessary! (refer to page 7)

DN15-100: Throttling plug as standard
(for max. permissible ΔP refer to: Flow diagram)

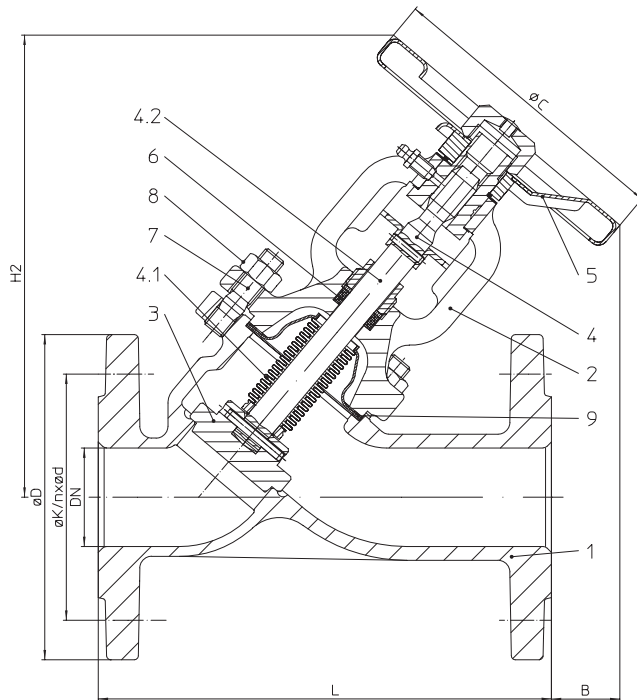
Selection of possible applications

Recycling facilities, chemical industry, hospital technology, process water installations, installations with aggressive media (other applications on request)

Selection of possible flow media

Process water, aggressive media, etc. (other flow media on request)

Parts

Pos.	Description	Fig. 52.069 / Fig. 54.069 / Fig. 55.069	Fig. 62.069 / Fig. 64.069 / Fig. 65.069
1	Body	GX5CrNiMo19-11-2, 1.4408 casted	
2	Bonnet	G-X 5 CrNiMoNb 19-11-2, 1.4581	GP240GH+N, 1.0619+N
3	Plug *	X6CrNiMoTi17 12 2, 1.4571	
4.1	Bellows seal *	X6CrNiMoTi17 12 2, 1.4571	
4.2	Stem *	X6CrNiMoTi17 12 2, 1.4571	
5	Handwheel	≤DN150: St (WEMA COR - coating) / >DN150: EN-JL1040, EN-GJL-250 (WEMA COR - coating)	≤DN150: St (epoxy-coating) / >DN150: EN-JL1040, EN-GJL-250 (epoxy-coating)
6	Packing ring *	Pure graphite	
7	Stud	A4-70	25CrMo4, 1.7218
8	Hexagon nut	A4	C35E, 1.1181
9	Gasket *	Pure graphite (CrNi laminated with graphite)	

* Spare part

Information / restriction of technical rules need to be observed!

Operating instructions can be ordered by phone +49 (0)5207 / 994-0 or fax +49 (0)5207 / 994-158 or -159.

A production allowance acc. to TRB 801 No. 45 exists

The engineer, designing a system or a plant, is responsible for the selection of the correct valve.

Dimensions

	DN	15	20	25	32	40	50	65	80	100	125	150	200
L	(mm)	130	150	160	180	200	230	290	310	350	400	480	600
H2	(mm)	195	195	205	205	235	235	265	295	380	415	480	615
ØC (PN16/25)	(mm)	126	126	126	126	150	150	175	175	225	300	400	520
ØC (PN40)	(mm)	126	126	126	126	150	150	175	225	300	300	400	520
B	(mm)	95	70	70	55	65	35	15	50	120	100	90	140
Travel	(mm)	6	6	8	8	13	13	16	20	25	32	40	50
Kvs-value	(m ³ /h)	5,7	6,8	12,7	16,8	35,8	47,7	77	107	174	279	406	709
Zeta-value	--	2,5	5,5	3,9	5,9	3,2	4,4	4,8	5,7	5,3	5	4,9	5,1

Zeta-value ... range of tolerance for Kvs-values acc. to VDI/VDE 2173

Standard-flange dimensions refer to page 9

Face-to-face dimension FTF series 1 according to DIN EN 558

Weights

Figure-No.	DN	15	20	25	32	40	50	65	80	100	125	150	200
52. / 54. / 62.069	(kg)	4	4,5	5,4	6,5	8,5	11,7	16	21,7	31,1	43,5	62	133
55. / 64. / 65.069	(kg)	4	4,5	5,4	6,5	8,5	11,7	16	21,7	31,1	43,5	62	133

Stop valve - Y-pattern with butt weld ends and bellows seal (Stainless steel 1.4571/1.4439)

Figure-No.	Nominal pressure	Material	Nominal diameter
55.066...60	PN40	1.4571	DN15-50
55.066...63	PN40	1.4439	DN15-50
larger nominal diameters (casted body) refer to page 5			
Butt weld ends according to DIN EN 12627 - 4 (refer to page 6)			
Test: • Test approvals TÜ.A/TÜV.AR.186-00 • German TA - Luft TÜV-Test-No. 088-945053			
At high differential pressures a balancing plug is necessary! (refer to page 7)			
Plug with marginal seat; stellited seat and plug standard			

Selection of possible applications

Recycling facilities, chemical industry, hospital technology, process water installations, installations with aggressive media (other applications on request)

Selection of possible flow media

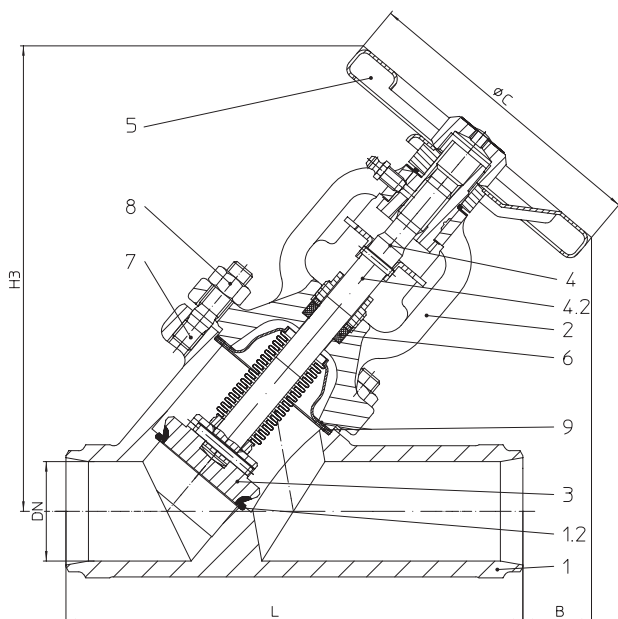
Process water, aggressive media, etc. (other flow media on request)

Parts

Pos.	Description	Fig. 55.066...60	55.066...63
1	Body	6CrNiMoTi17-12-2, 1.4571 forged	X2CrNiMoN17-13-5, 1.4439 forged
1.2	Seat ring	Stellit 21	
2	Bonnet	G-X5CrNiMoN19-11-2, 1.4581 casted	X2CrNiMoN17-13-5, 1.4439 forged
3	Plug *	X6CrNiMoTi17 12 2, 1.4571 / Stellit 6	X2CrNiMoN17-13-5, 1.4439 / Stellit 21
4.1	Bellows seal *	X6CrNiMoTi17 12 2, 1.4571	Hastelloy C-276
4.2	Stem *	X6CrNiMoTi17 12 2, 1.4571	X2CrNiMoN17-13-5, 1.4439
5	Handwheel	St (epoxy-coating)	
6	Packing ring *	Pure graphite	
7	Stud	A2-70	
8	Hexagon nut	A2	
9	Gasket *	Pure graphite (CrNi laminated with graphite)	

* Spare part

Information / restriction of technical rules need to be observed!

Operating instructions can be ordered by phone +49 (0)5207 / 994-0 or fax +49 (0)5207 / 994-158 or -159.

A production allowance acc. to TRB 801 No. 45 exists

The engineer, designing a system or a plant, is responsible for the selection of the correct valve.

Dimensions

	DN	15	20	25	32	40	50
L	(mm)	130	150	160	180	200	230
H3	(mm)	205	205	210	210	235	235
ØC	(mm)	126	126	126	126	150	150
B	(mm)	95	70	70	55	65	35
Travel	(mm)	6	6	8	8	13	13
Kvs-value	(m ³ /h)	4,23	6,97	9,83	13	28,2	35
Zeta-value	--	4,5	5,3	6,5	9,9	5,1	8,1

Zeta-value ... range of tolerance for Kvs-values acc. to VDI/VDE 2173

Face-to-face dimension ETE series 1 according to DIN EN 12982

Weights

Figure-No.	DN	15	20	25	32	40	50
55.066	(kg)	3,2	3,6	4	4,8	6,8	8,5

Stop valve - Y-pattern with butt weld ends and bellows seal (Stainless steel 1.4581/1.4439)

Figure-No.	Nominal pressure	Material	Nominal diameter
54.066...60	PN25	1.4581	DN200
55.066...60	PN40	1.4581	DN65-150
54.066...63	PN25	1.4439	DN200
55.066...63	PN40	1.4439	DN65-150
smaller nominal diameters (forged body) refer to page 4			
Butt weld ends according to DIN EN 12627 - 4 (refer to page 6)			
Test: • Test approvals TÜ.A/TÜV.AR.186-00 • German TA - Luft TÜV-Test-No. 088-945053			
At high differential pressures a balancing plug is necessary! (refer to page 7)			
Plug with marginal seat; stellited seat and plug standard			

Selection of possible applications

Recycling facilities, chemical industry, hospital technology, process water installations, installations with aggressive media (other applications on request)

Selection of possible flow media

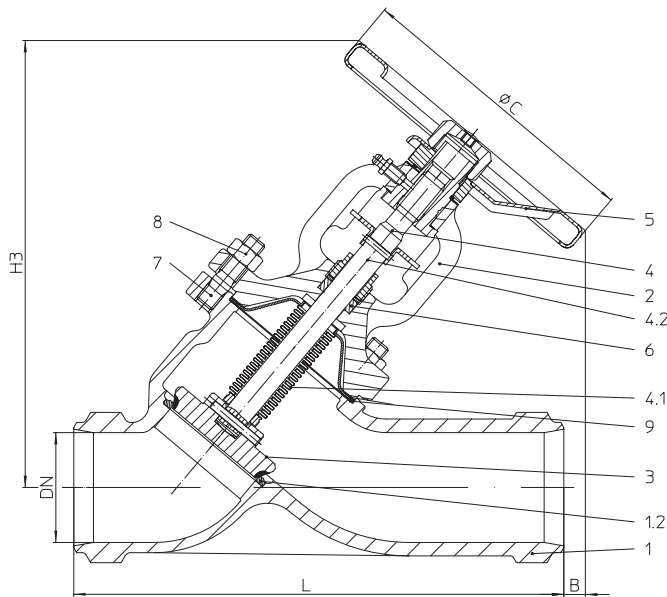
Process water, aggressive media, etc. (other flow media on request)

Parts

Pos.	Description	Fig. 55.066...60	55.066...63
1	Body	G-X5CrNiMoN19-11-2, 1.4581 casted	G-X3CrNiMoN17-13-5, 1.4439 casted
1.2	Seat ring	Stellit 21	
2	Bonnet	G-X5CrNiMoN19-11-2, 1.4581 casted	DN 65 - 80: X2CrNiMoN17-13-5, 1.4439 forged DN 100 - 200: G-X3CrNiMoN17-13-5, 1.4439 casted
3	Plug *	X6CrNiMoTi17 12 2, 1.4571 / Stellit 6	X2CrNiMoN17-13-5, 1.4439 / Stellit 21
4.1	Bellows seal *	X6CrNiMoTi17 12 2, 1.4571	Hastelloy C-276
4.2	Stem *	X6CrNiMoTi17 12 2, 1.4571	X2CrNiMoN17-13-5, 1.4439
5	Handwheel	≤DN150: St (epoxy-coating) / >DN150: EN-JL1040, EN-GJL-250 (epoxy-coating)	
6	Packing ring *	Pure graphite	
7	Stud	A2-70	
8	Hexagon nut	A2	
9	Gasket *	Pure graphite (CrNi laminated with graphite)	

* Spare part

Information / restriction of technical rules need to be observed!

Operating instructions can be ordered by phone +49 (0)5207 / 994-0 or fax +49 (0)5207 / 994-158 or -159.

A production allowance acc. to TRB 801 No. 45 exists

The engineer, designing a system or a plant, is responsible for the selection of the correct valve.

Dimensions

	DN	65	80	100	125	150	200
L	(mm)	290	310	350	400	480	600
H3	(mm)	265	295	425	455	510	650
ØC (PN25)	(mm)	--	--	--	--	--	520
ØC (PN40)	(mm)	175	225	300	300	400	--
B	(mm)	15	50	120	100	90	140
Travel	(mm)	16	20	25	32	40	50
Kvs-value	(m³/h)	97,6	121,2	189,8	327,6	444	895
Zeta-value	--	3	4,5	4,4	3,6	4,1	3,2

Zeta-value ... range of tolerance for Kvs-values acc. to VDI/VDE 2173

Face-to-face dimension ETE series 1 according to DIN EN 12982

Weights

Figure-No.	DN	65	80	100	125	150	200
54. / 55.066	(kg)	10	13,6	32	45	66	135

L = Face-to-face dimension
 Edge shaping acc. to DIN EN 25817

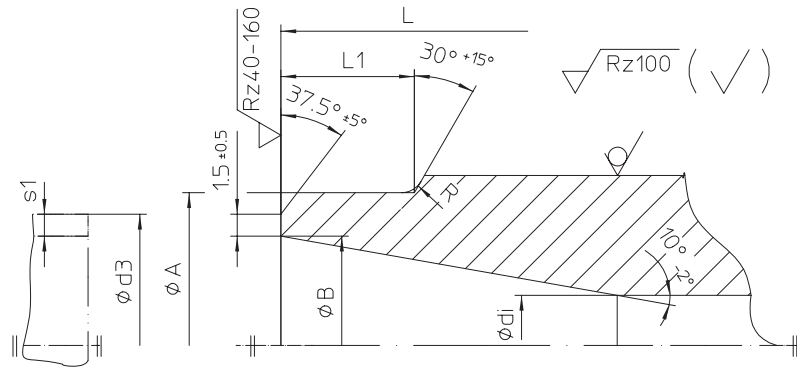
Butt weld ends according to DIN EN 12627 - 4

	DN	15	20	25	32	40	50	65	80	100	125	150	200
L	(mm)	130	150	160	180	200	230	290	310	350	400	480	600
ØA	(mm)	22	28	35	44	50	62	77	91	117	144	172	223
ØB	(mm)	17,3	22,3	28,5	37,2	43,1	53,9	68,9	80,9	104,3	130,7	157,1	204,9
Ødi	(mm)	15	20	25	32	40	50	65	80	100	125	150	200
R	(mm)	3	3	3	3	3	3	3	3	3	3	3	5
L1	(mm)	10	10	10	10	10	10	10	12	14	18	20	20
Ød3	(mm)	21,3	26,9	33,7	42,4	48,3	60,3	76,1	88,9	114,3	139,7	168,3	219,1
s1	(mm)	2,	2,3	2,6	2,6	2,6	3,2	3,6	4,	5,	4,5	5,6	7,1

Face-to-face dimension ETE series 1 according to DIN EN 12982.

Butt weld ends according to DIN EN 12627 - 4.

Weld joint according to DIN EN 29692 code number 1.3.3.

The material used for ARI valves with butt weld ends are:

X6CrNiMoTi17-12-2, 1.4571 acc. to DIN EN 10088-1,

GX5CrNiMoN19-11-2, 1.4581 acc. to DIN EN 10213-1,

G-X2CrNiMoN17 13 5, 1.4439 acc. to DIN EN 10088-1 and VdTÜV WB458.

Based on our experience we recommend electric welding process for connecting valves or strainers with tubes or with each other

Lime based electrodes with an appropriate composite material should be used as filler material for welding.

Gas welding should be avoided.

Due to the different material composition and material thickness of valves and tubes, gas welding is more susceptible to produce faults than electric welding (hardness cracks, coarse-grained structure).

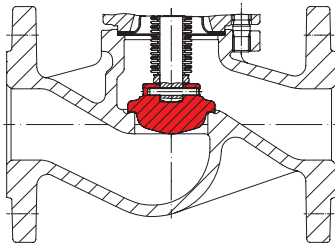

Regulating plug
 (for max. permissible ΔP refer to: Flow diagram)

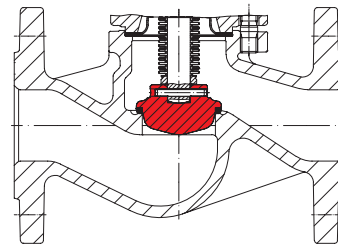

Regulating plug with soft seal
 Max. operating temperature 200°C at PTFE + 25% carbon
 (for max. permissible ΔP refer to: Flow diagram)

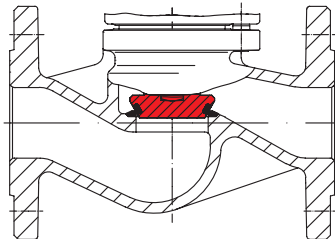

Isolation plug with marginal seat; stellited seat and plug (standard at Fig. 066)

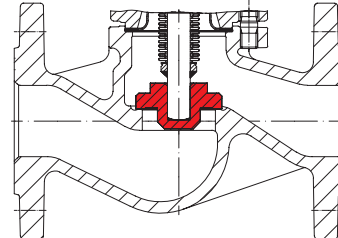

Screw down non-return plug
 max. differential pressure, refer to table of pressure balancing plugs.
 Set pressure 0,05 bar
 Important: Installation of the valve only in horizontal pipe runs with vertical stem.

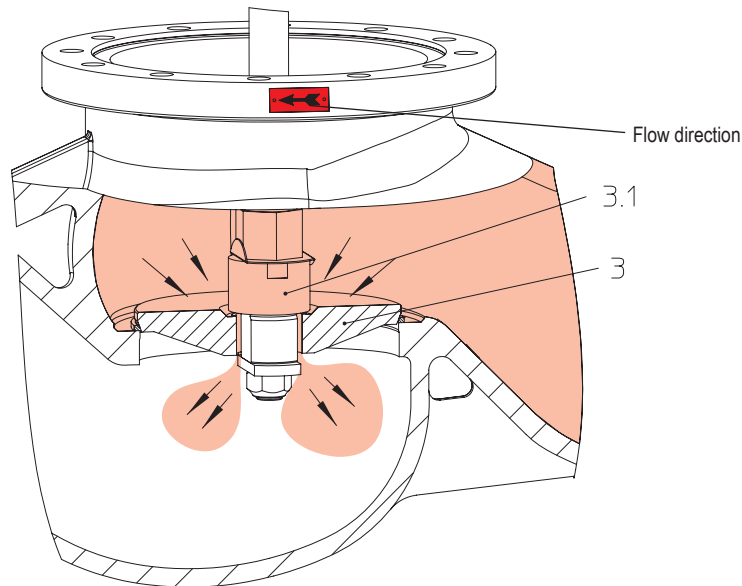

Valves with balancing plugs have to be installed with medium flowing over the plug (3) as indicated by flow direction arrow on valve body and the stem is vertically upright.
 Working principles:

When the valve is closed, anticlockwise rotation of the hand wheel lifts the pilot plug (3.1) off the larger balancing plug (3).

This allows the medium to pass through the plug and equalizes the pressure of the medium under the plug (3). After the pressures have been equalized within the valves stated in the table, the valve can be opened by turning the valve further with normal manual force.

Balancing plugs are fully effective only in closed systems.

The pressures of the medium on either side of the plug can not be equalized if the medium is discharged into open air.

A bypass line or some other arrangement is necessary if too much time is required for pressure equalization owing to the volume in the piping system.

ARI-stop valves with differential pressures exceeding the following pressures, have to be fitted with pressure balancing plugs

	DN	125	150	200
Differential pressure (ΔP)	(bar)	25	21	14

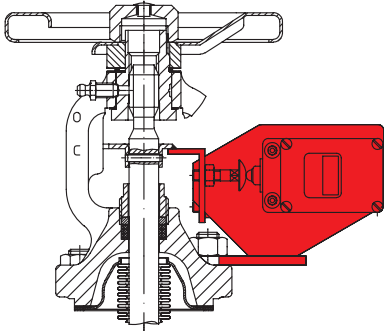

Limit switch

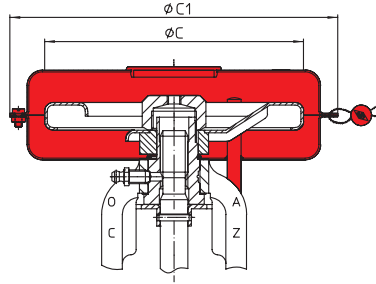

Hood valve
 (tamper resistant handwheel cover)

Size	DN	ØC	ØC1
	(mm)	(mm)	(mm)
I	15-32	126	170
II	40-80	150	190
III	100-150	225	330

Handwheel-Ø from DN 65 reduced!

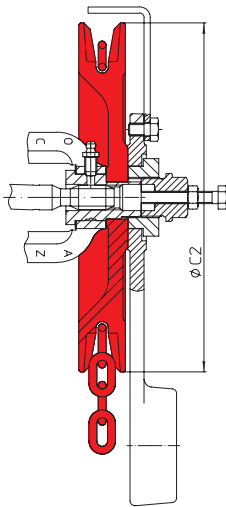

Chain wheel

DN	ØC2	Weight
	(mm)	(kg)
15-32	180	2,5
40-80	220	7
100-150	260	8,9
200-	300	11

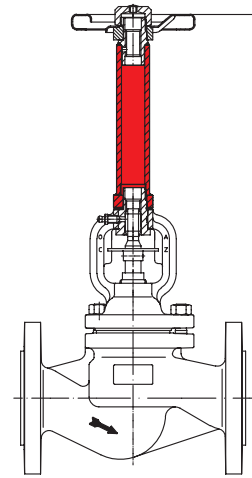

Stem extension (please specify height in your order)

Accessories: Travel limiter

Standard: Lubricating nipple, locking device

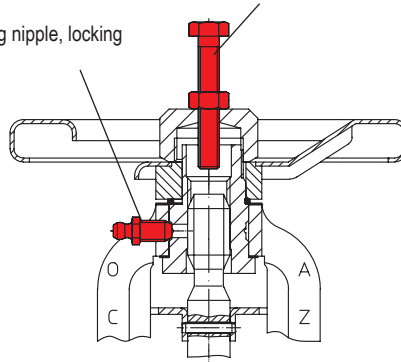

Lubricating nipple / locking device / travel limiter

Application of lubricating nipples
 Functions:
 1. Lubrication
 (prevents the handwheel jamming)
 2. Locking screw
 (allows valve to be locked-off at desired travel)
 3. Lubrication an locking
 (lubication with locked handwheel possible)

Travel limiter
 (Accessories are not included !)

DN	Hexagon screw
(mm)	(mm x mm)
15-80	M8 x 55
100	M12 x 70
125-150	M12 x 80
200	M12 x 100

Standard-flange dimensions

Flanges acc. to DIN EN 1092-1/-2 (Flangeholes / -thickness tol. acc. to DIN 2533/2544/2545)

DN		(mm)	15	20	25	32	40	50	65	80	100	125	150	200
PN16	ØD	(mm)	95	105	115	140	150	165	185	200	220	250	285	340
PN16	ØK	(mm)	65	75	85	100	110	125	145	160	180	210	240	295
PN16	n x Ød	(mm)	4x14	4x14	4x14	4x18	4x18	4x18	4x18	8x18	8x18	8x18	8x22	12x22
PN25	ØD	(mm)	95	105	115	140	150	165	185	200	235	270	300	360
PN25	ØK	(mm)	65	75	85	100	110	125	145	160	190	220	250	310
PN25	n x Ød	(mm)	4x14	4x14	4x14	4x18	4x18	4x18	8x18	8x18	8x22	8x26	8x26	12x26
PN40	ØD	(mm)	95	105	115	140	150	165	185	200	235	270	300	375
PN40	ØK	(mm)	65	75	85	100	110	125	145	160	190	220	250	320
PN40	n x Ød	(mm)	4x14	4x14	4x14	4x18	4x18	4x18	8x18	8x18	8x22	8x26	8x26	12x30

Pressure-temperature-ratings acc. to DIN EN 1092-1

Material			-60°C to <-10°C	-10°C to 100°C	150°C	200°C	250°C	300°C	350°C	400°C
1.4408	16	(bar)	16	16	14,5	13,4	12,7	11,8	11,4	10,9
1.4408	25	(bar)	25	25	22,7	21	19,8	18,5	17,8	17,1
1.4408	40	(bar)	40	40	36,3	33,7	31,8	29,7	28,5	27,4
1.4581	16	(bar)	8	16	15,6	14,9	14,1	13,3	12,8	12,4
1.4581	25	(bar)	12,5	25	24,5	23,3	22,1	20,8	20,1	19,5
1.4581	40	(bar)	20	40	39,2	37,3	35,4	33,3	32,1	31,2

Pressure-temperature-ratings acc. to manufacturers standard

Material			-60°C to <-10°C	-10°C to 20°C	100°C	150°C	200°C	250°C	300°C	350°C	400°C
1.4439	16	(bar)	8	16	15,5	14,6	13,9	13,2	12,4	12	11,7
1.4439	25	(bar)	12,5	25	24,2	22,9	21,8	20,7	19,4	18,8	18,2
1.4439	40	(bar)	20	40	38,8	36,6	34,8	33,1	31,1	30	29,2

Intermediate values for max. permissible operational pressures can be determined by linear interpolation of the given temperature / pressure chart.

Please indicate when ordering

- Figure-No.
- Nominal pressure
- Nominal diameter
- Special design / accessories

Example:

Figure 55.046; Nominal pressure PN40; Nominal diameter DN100.

 Dimensions in mm
 Weights in kg
 1 bar $\hat{=}$ 10⁵ Pa $\hat{=}$ 0,1 MPa
 Kvs in m³/h



Technology for the Future.
GERMAN QUALITY VALVES

ARI-Armaturen Albert Richter GmbH & Co. KG, D-33756 Schloß Holte-Stukenbrock,
Tel. +49 52 07 / 994-0, Telefax +49 52 07 / 994-158 or 159 Internet: <http://www.ari-armaturen.com> E-mail: info.vertrieb@ari-armaturen.com